

DS-130BT

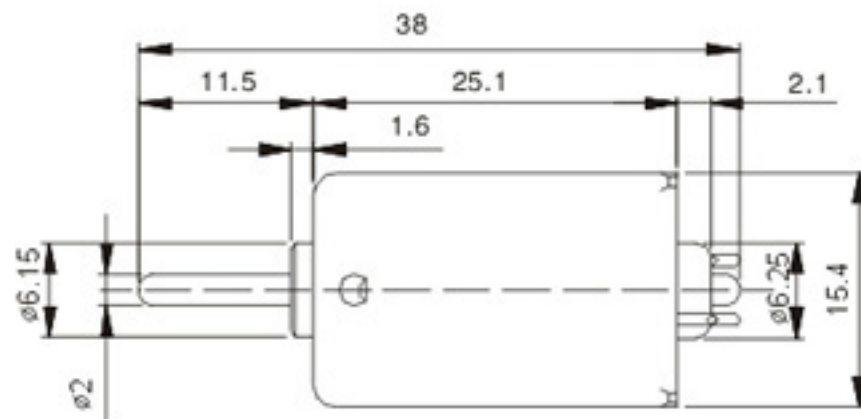

WEIGHT: 21.5g (APPROX)

MODEL	VOLTAGE		NO LOAD		AT MAXIMUM EFFICIENCY					STALL		
	OPERATING RANGE	RATED	SPEED	CURRENT	SPEED	CURRENT	TORQUE		OUTPUT	TORQUE		CURRENT
	V	V	rpm	A	rpm	A	g.cm	mN.m	W	g.cm	mN.m	A
DS-130BT	1.5 ~ 3.0	1.5	12600	0.38	9700	0.91	3.3	0.32	0.38	14.2	1.4	2.44
DS-130BT	1.5 ~ 3.0	3	5000	0.095	4110	0.44	17.7	1.73	0.76	99	9.7	2.0

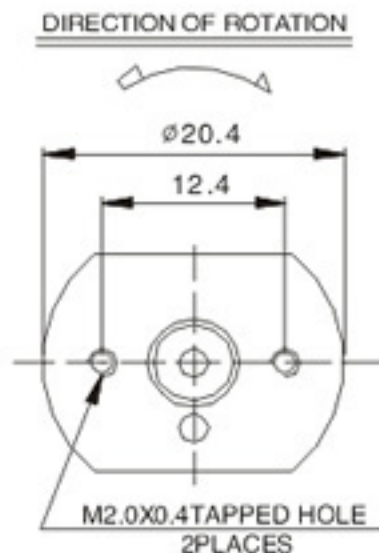